





collections

Minas

Crocodile

Eye

Armada

Layairo1

Layairo2

Masterpiece

Polyline

CoffeeTable

Negative

Stealth

L

DiningTable

Clover

Concrete

Lamps

...contents



...about us



HOOKL und STOOL is a new manufacturer and editor of contemporary design furniture and objects.

In every pure handmade piece we make, you can feel and enjoy in tradition of craftsmanship and experience we have in solid wood.

As a design editor, HOOKL und STOOL carefully selects outstanding craftsmen and manufacturers of metal parts, hand woven textile ,thick leather, combining it with the solid wood.

We work exclusively with talented designers who understand and share our design philosophy and passion, in order to provide quality, original and functional products for the high end, residential and contract markets.



Process

HOO KL und ST OOL furniture is made of carefully selected sorts of solid wood as walnut, dark elm, oak, cherry, ash, acacia and steamed acacia. Our artisans use only natural waxes and oils for wooden finishing.

Likewise, all other materials used for our products like upholstery, leather, fur, metal, glass and concrete, define supreme quality of handmade finishing.

Products

The collection offers a range of seating, furniture, tables, lighting, occasional furniture, accessories and small decorative objects. HOO KL und ST OOL aims at opening its collection to the new markets such as outdoor and contract. In order to achieve this, HOO KL und ST OOL starts with new partnerships involving manufacturers and designers in keeping with the brand's philosophy - combining artisanal craftsmanship with contemporary designs using both traditional crafts and innovative techniques, mixing solid wood with metal, glass, leather, fur, upholstery and concrete.

With unique code for each piece, our clients are provided with the opportunity of online products tracking, in order to improve client-manufacturer communication and maintenance of the products.



high armchair, eu walnut, fabric no6, no7, 01-01-01
lamp relife, eu walnut, steel natural, edison bulbs 6x40W

001

Windoas collection



high armchair, eu walnut, fabric no6, no7, 01-01-01



minas collection

This collection consists of armchair and coffee table. Main feature of this collection is spherical shape of armchair, which is made from two semi-oval shapes separated from each other, which resemble a coffee grain. That part is made from plexiglass substructure. Left or right half as well as front and rear part of the sphere can be upholstered with various materials in terms of texture and colour.

Additional grace of the armchair lies in its legs, which are made from solid wood and have the shape of Nordic sleighs and gracefully fit in the upper part. Esthetic detail is the adjustable head cushion which moves up and down, when turning the decorative wooden bolt located in the rear part of the armchair. The armchair is characterized by exceptional ergonomics which comes from its spherical shape.



minas high armchair
designer: aleksandar ugresic
launched: 2015
code: 01-01-02
dimension: w75, h98, h99
finishing: legs solid wood, seat fabric, wool
packaging: five layer cardboard box
1 piece/packaging





left, high armchair 01, eu walnut, wool no36, code 01-02-02
right, high armchair 02, eu walnut, fabric no21, code 01-02-06

collection

Croccodile

002



crocodile collection

Crocodile collection consists of two armchairs,
leg rest and coffee table.

The name of collection comes from characteristic composition of the front legs and arm rest on the armchair (which resemble crocodile jaws). Extremely sharp, broken lines dominate both on the wooden structure and in upholstered back rest and seat, additionally emphasizing the sharpness of the piece. Armchair is made in two versions (face and mirror) which is achieved by switching left and right wooden frame on the armchair. The armchair is accompanied by ergonomically adjustable leg rest, the upper upholstered part of which can be skewed 20 degrees left or right. The armchair is accompanied by coffee table which also has the crocodile detail, but this time in the position of the leg. Buyer can choose type of wood and type and colour of material, which can be fabric or wool.



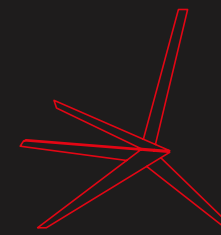

crocodile high armchair 01
designer: aleksandar ugresic
launched: 2015
code: 01-02-02
dimension: w74, l92, h99
finishing: legs solid wood (natural oil, hard wax),
seat fabric, wool
packaging: five layer cardboard box
1 piece/packaging

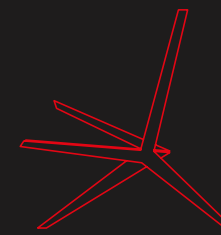

crocodile high armchair 02
designer: aleksandar ugresic
launched: 2015
code: 01-02-06
dimension: w74, l92, h99
finishing: legs solid wood (natural oil, hard wax),
seat fabric, wool
packaging: five layer cardboard box
1 piece/packaging

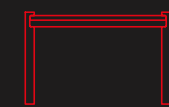

crocodile coffee table
designer: aleksandar ugresic
launched: 2015
code: 01-02-05
dimension: small w65, l39, h39
big w100, l50, h39
finishing: solid wood (natural oil, hard wax)
packaging: five layer cardboard box
1 piece/packaging



high armchair, eu walnut, wool no13 , 01-03-02

003

EYE collection

high armchair, eu walnut, wool no13 , 01-03-02
foot rest, eu walnut, wool no13 , 01-03-04





eye collection

Eye collection consists of armchair, leg rest, 2 or 3 seater sofa. Main characteristic of this collection lies in its emphasized spherical side of each piece in the collection, which is made from solid wood, additional graced with widened parts in the back or seat. These parts are made from knotted segments of tree trunk, where rings have spiral form and resemble human eye, hence the name of the whole collection.

Also, 'eye' gives exceptional ergonomics to each piece, as the upholstered part follows their shape. Additional esthetics and 3 D effect can be seen in slightly conical legs which form a conical shape. Asymmetrical, hand-made wooden buttons with emphasized thread in different colour, make a tasteful detail on the buttons.



high armchair, eu walnut, wool no13 , 01-03-02
foot rest, eu walnut, wool no13 , 01-03-04



eye high armchair
designer: aleksandar ugresic
launched: 2015
code: 01-03-02
dimension: w75, l88, h99
finishing: legs solid wood (natural oil, hard wax),
seat fabric, wool
packaging: five layer cardboard box
1 piece/packaging

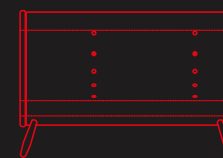

eye sofa
designer: aleksandar ugresic
launched: 2015
code: 01-03-05
dimension: w144, l88, h99
finishing: legs solid wood (natural oil, hard wax),
seat fabric, wool
packaging: five layer cardboard box
1 piece/packaging



eye foot rest
designer: aleksandar ugresic
launched: 2015
code: 01-03-04
dimension: w75, l39, h40
finishing: solid wood (natural oil, hard wax)
packaging: packed with armchair



high armchair, american walnut, thick leather no1, 01-04-01
coffee table, american walnut, 01-04-05

high armchair, american walnut, thick leather no1, 01-04-01
coffee table, american walnut, 01-04-05



armada collection

Armada collection is inspired by the colossal fleet which conquered the world.

This collection is composed by high armchair, chaise lounge, foot rest stool and coffee table.

Combining the tiniest materials gives this armchair an exceptional feeling of lightness. With its highly developed static, the constructive part of the solid wood is made of steel, with various finishing as polished, chromed, brass or burnished steel, which emphasizes the elegance and sharpness this vigorous design has.

The seater consists of the construction made of thin steel and covering made of high quality leather or fur.

Unique magnet system connects different type of pillows and other gadgets with the seater part.

Armada collection is made of different type of solid wood, like elm, walnut.

Feel its power and anchors aweigh!





high armchair, american walnut, thick leather no1, 01-04-01
foot rest, american walnut, 01-04-03



high armchair, american walnut, thick leather no1, 01-04-01

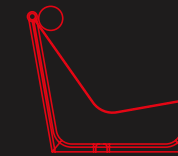

armada high armchair
designer: zoran jedrejic
launched: 2014
code: 01-04-01
dimension: w60, l95, h80
w60, l95, h86
finishing: legs solid wood (natural oil, hard wax),
seat thick leather
packaging: five layer cardboard box
1 piece/packaging

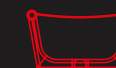

armada foot rest
designer: zoran jedrejic
launched: 2014
code: 01-04-03
dimension: w60, l37, h33
finishing: solid wood (natural oil, hard wax),
seat thick leather
packaging: packed with armchair

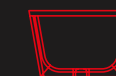

armada coffee table
designer: zoran jedrejic
launched: 2014
code: 04-01-05, 04-01-06
dimension: small w60, l40, h38
big w100, l50, h38
finishing: solid wood (natural oil, hard wax)
packaging: five layer cardboard box
1 piece/packaging



high armchair, cherry, fabric no 16, no 21, 01-05-01
foot rest, cherry, fabric no 16, no 21, 01-05-09

005

01
Laverne
collection



layair 01 collection

Defined with simple, accurate forms, this collection evokes all the beauty of the solid wood. Legs make the identifiable ornament characteristic to all the products from this collection.

Upholstery is removable, and it can be double-faced, made for hot/warm climate or hand woven on request.

It is composed by high armchair, low armchair, foot rest stool, stool and coffee table.

Like all our products, it can be made of different sorts of solid wood like elm, walnut, oak, cherry.





left, high armchair, cherry, fabric no16, no21, 01-05-01

foot rest, acacia, fabric no 16, no 21, 01-05-09

right, low armchair layair o2, eu walnut, upholstery leather no 25, 01-06-06

coffee table, acacia, 01-05-18



high armchair, cherry, fabric no16, no21, 01-05-01

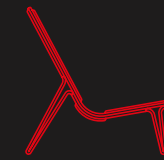

layair 01 high armchair
designer: zoran jedrejic
launched: 2014
code: 01-05-01
dimension: w60, l95, h87
finishing: solid wood (natural oil, hard wax),
seat fabric, wool, leather,
handwoven on request
packaging: five layer cardboard box
1 piece/packaging

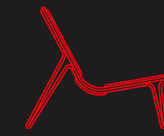

layair 01 low armchair
designer: zoran jedrejic
launched: 2014
code: 01-05-05
dimension: w60, l91, h71
finishing: solid wood (natural oil, hard wax),
seat fabric, wool, leather,
handwoven on request
packaging: five layer cardboard box
1 piece/packaging



layair foot rest
designer: zoran jedrejic
launched: 2014
code: 01-05-09 (01-06-09)
dimension: w36, l60, h32
finishing: solid wood (natural oil, hard wax),
seat fabric, wool, leather,
handwoven on request
packaging: packed with armchair



layair coffee table
designer: zoran jedrejic
launched: 2014
code: 01-05-18 (01-06-18)
dimension: w36, l60, h32
finishing: solid wood (natural oil, hard wax)
packaging: five layer cardboard box
1 piece/packaging



layair stool
designer: zoran jedrejic
launched: 2014
code: 01-05-13 (01-06-13)
dimension: w40, l36, h38
finishing: solid wood (natural oil, hard wax),
seat fabric, wool, leather,
handwoven on request
packaging: five layer cardboard box
1 piece/packaging



low armchair, american walnut, upholstery leather no25, 01-06-06
coffee table, american walnut, newspaper holder leather no25, 01-06-17

006

Levy's 02

collection



left, high armchair layair 01, cherry, fabric no16, no21, 01-05-01
right, low armchair, eu walnut, upholstery leather no25, 01-06-06



layair 02 collection

Defined with simple, accurate forms, this collection evokes all the beauty of the solid wood. Legs make the identifiable ornament characteristic to all the products from this collection.

Upholstery is removable.

It is composed by high armchair, low armchair, foot rest stool, stool and coffee table.

Like all our products, it can be made of different sorts of solid wood like elm, walnut, oak, cherry.



low armchair, american walnut, upholstery leather no25, 01-06-06
coffee table, american walnut, newspaperholder leather no25, 01-06-17
stool, american walnut, 01-06-13

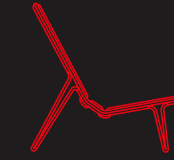

layair 02 high armchair
designer: zoran jedrejic
launched: 2014
code: 01-06-01
dimension: w60, l95, h87
finishing: solid wood (natural oil, hard wax),
seat fabric, wool, leather,
handwoven on request
packaging: five layer cardboard box
1 piece/packaging

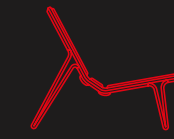

layair 02 low armchair
designer: zoran jedrejic
launched: 2014
code: 01-06-05
dimension: w60, l91, h71
finishing: solid wood (natural oil, hard wax),
seat fabric, wool, leather,
handwoven on request
packaging: five layer cardboard box
1 piece/packaging



layair foot rest
designer: zoran jedrejic
launched: 2014
code: 01-05-09 (01-06-09)
dimension: w36, l60, h32
finishing: solid wood (natural oil, hard wax),
seat fabric, wool, leather,
handwoven on request
packaging: packed with armchair



layair coffee table
designer: zoran jedrejic
launched: 2014
code: 01-05-18 (01-06-18)
dimension: w36, l60, h32
finishing: solid wood (natural oil, hard wax)
packaging: five layer cardboard box
1 piece/packaging



layair stool
designer: zoran jedrejic
launched: 2014
code: 01-05-13 (01-06-13)
dimension: w40, l36, h38
finishing: solid wood (natural oil, hard wax),
seat fabric, wool, leather,
handwoven on request
packaging: five layer cardboard box
1 piece/packaging

collection

Masterpiece

007

This collection, inspired by the philosophy of the Scandinavian design masters of the 50ies, by far is composed of several armchairs. Each piece is slightly transformed comparing to the originals with the different choice of materials and also with redesigning particular elements of the structure, regarding the forms, connections and leather details.

from left to right:
low armchair MP02, cherry, fur, 01-07-02
low armchair MP03, elm, thick leather (colour on request), 01-07-03
low armchair MP01, eu walnut, 01-07-01
low armchair MP04, cherry, thick leather no1, 01-07-04

masterpiece collection

MP 01

Cees Braakman was one of the Dutch most influential designers. Differently from the original, the armchair on the photo above is entirely made of solid wood. Despite that, exceptional functionality and ergonomics are characteristic for this piece. Apart from European oak used for making the piece above, dark elm would fit it perfectly.





masterpiece collection

MP 02

Hans Wegner, was a world renowned Danish furniture designer. His style is often described as Organic Functionality. In his lifetime he designed over 500 different chairs, over 100 of which were put into mass production and many of which have become recognizable design icons. Armchair on the photo above is a very rare model. It is made of solid wood, fur and stainless steel shackle which holds the seater and the backrest. Like for every Hans Wegner's armchair, exceptional ergonomics is characteristic for this piece. All materials used for making this armchair (different sorts of solid wood, also combining different sorts of solid wood, fur, leather, textile or Dypon Tyvek as an upholstery for the pillows, different finishing of the metal parts) could be made on client's request.

masterpiece collection

MP 03

Børge Mogensen designed the Hunting Chair in 1950. The Hunting Chair's rounded armrests, seat, and back that adjust to the body's weight make it a very comfortable chair. Despite the front seat edge height of just 30 cm above the floor, the armrests make the chair easy to get up from. The frame is made of solid wood, while the seat and back are of thick leather, with adjustable straps. This rustic and masculine combination of materials, which give a very special patina, was further developed by Mogensen.





masterpiece collection

MP 04

Uno & Östen Kristiansson were Swedish Interior and Furniture designers. They mostly designed Lighting object, this Hunting Chair was one of they rare furniture projects. The frame is made of solid wood, while the seat and back are of thick leather, with adjustable straps. The Hunting Chair's rounded armrests, seat, and back that adjust to the body's weight make it a very comfortable chair.

masterpiece collection

MP05

Lisa Johansson-Pape was a Finnish designer best known for her work in lighting. She was the most significant Finnish lighting designer in the second half of the 1900s. Her priorities were first about the functions then the design. Stool is one of the few rare pieces of furniture she designed.



Stool MP05, high, american walnut, 01-07-05
Stool MP05, low, acacia, 01-07-06



masterpiece MP01
designer: cees brakman
code: 01-07-01
dimension: w53, l73, h70
finishing: solid wood (natural oil, hard wax)
packaging: five layer cardboard box
1 piece/packaging

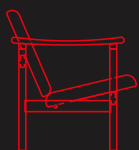

masterpiece MP02
designer: hans wegner
code: 01-07-02
dimension: w71, l74, h75
finishing: solid wood (natural oil, hard wax),
seat fur
packaging: five layer cardboard box
1 piece/packaging



masterpiece MP03
designer: børge mogensen
code: 01-07-03
dimension: w70, l90, h68
finishing: solid wood (natural oil, hard wax),
seat thick leather
packaging: five layer cardboard box
1 piece/packaging



masterpiece MP04
designer: uno & östen kristiansson
code: 01-07-04
dimension: w62, l100, h78
finishing: solid wood (natural oil, hard wax),
seat thick leather
packaging: five layer cardboard box
1 piece/packaging



masterpiece MP05
designer: lisa johansson pape
code: 01-07-05 (01-07-06)
dimension: low w28, l28, h35
high w39, l39, h45
finishing: solid wood (natural oil, hard wax)
packaging: five layer cardboard box
1 piece/packaging



Low armchair MP03; elm, thick leather
(colour on request), 01-07-03



From left to right:
Coffee table No1, eu walnut, steel coloured, 02-01-01
Hi-fi rack, eu walnut, steel coloured, 02-01-04
Coffee table No2, eu walnut, steel coloured, 02-01-02

008

Polymie collection



polyline collection

Polyline collection consists of coffee tables, hi-fi rack, self-supported and wall bookshelves, work table with chair, as well as kitchen and bathroom accessories.

The whole collection is made from the combination of solid wood and perforated steel of 3 mm thickness, which is seamed in the wooden structure. The steel that bends in different ways makes statical, esthetical and functional element of each individual piece. The name of the collection Polyline comes from playfulness of line forms of the steel on side edges. It is possible to choose wood type as well as colour of steel of each individual piece, making it easy for the buyer to personalize the appearance of this piece.



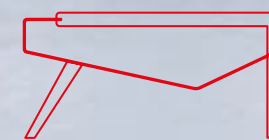

no1 coffee table
designer: aleksandar ugresic
launched: 2015
code: 02-01-01
dimension: w80, l47, h39
finishing: solid wood (natural oil, hard wax),
metal colored steel
packaging: five layer cardboard box
1 piece/packaging





noz coffee table
designer: aleksandar ugresic
launched: 2015
code: 02-01-02 (02-01-03)
dimension: small w100, l47, h39
 big w120, l60, h39
finishing: solid wood (natural oil, hard wax),
 metal colored steel
packaging: five layer cardboard box
 1 piece/packaging

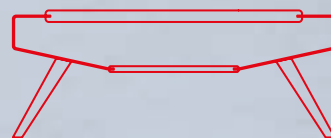





hi-fi rack
designer: aleksandar ugresic
launched: 2015
code: 02-01-04
dimension: small w95, l36, h50
big w135, l36, h50
finishing: solid wood (natural oil, hard wax),
metal colored steel
packaging: five layer cardboard box
1 piece/packaging

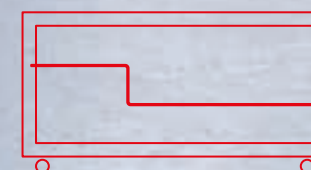



Coffee table robust, oak sandblasted, 02-02-02

009

collection

Coffee Table

coffee table collection

This collection is composed by several coffee tables, fulfilling the variety of clients' esthetic requests. Finishing with the high quality level of the material processing, regardless its solid wood, metal or glass is characteristic for this collection. Beside the wide range of different sorts of solid wood, it is also possible to choose the finishing of the metal (chromed, brass or burnished), likewise to choose the processing of the glass edges (transparent, etched or rounded).





coffee table mangata

Dining table made from solid wood of increased strength, designed with the idea of the rational utilization of wood mass, whereby the savings are reflected in the drafting panel thickness of 25mm, and the structural stability is achieved by cross-fertilization of elements, and using surface properties of elements of small thickness. Simple and purified form is characterized by a synthesis of form and visual constructive standard of high level of stability. Variations in the embodiment provides the use of combining different types of wood, as well as alternatives in dimensions because the dining version is manufactured in twice smaller proportion as a club table titled MINIMANGATA.





coffee table maru

Table is designed to be manufactured from solid wood of middle and high hardness, such as oak, walnut, elm or similar exotic species. Names MARU and MINIMARU define production in two sizes, where the main dining table has a rectangular dimensions of 220 x 90 x 72cm, while other is proportionally half size manufactured as a club table of dimensions 110 x 45 x 36cm. The tabletop is 25 mm thick and is made of two pieces calibrated in the same dimensions and jointed longitudinally with the cogged joint. The shorter side of the plate is reduced to a thickness of 8mm by wedge processing, with the idea that from that perspective solid plate looks sharply and elegantly. To avoid deformation of the plate and its stabilization, it is also detached wedge-processed lower plate, which is imperceptible due to reduced thinned edges.

The table legs which are attached to the bottom side are the L elements of square section 80 x 80mm and get the form of a right triangle by removing excess material, which facilitates the overall aesthetic and weight, and does not endanger the structural stability.



Robust coffee table, CT 01

As its name says, this coffee table radiates with an exceptional plenitude and robustness.

Its roughness is additionally pointed with an effect of sandblasted sides and firm legs.

Table top consists of 15 cubes which are additionally pointed with mutual interception making discrete cannelures.

Considering its character, proud-spirited sorts of wood as walnut, dark elm or oak perfectly fits it.

Wooden finishing with the natural oils and waxes.



Coffee table No 1

Simple coffee table with entirely basic lines is ideal for mixing with different types of armchairs. Its dynamic comes from its slantwise edges of the table top and its conically positioned legs, becoming slightly narrower touching the floor. It could be made of various sorts of wood, which would give it entirely different character.

Coffee table TY

Wood, glass and metal combined coffee table. Complete duality of its character is what makes this coffee table unusual. It is shown through clearly divided top, also through its legs. The top combined of the 10mm tempered glass on the one half and the solid wood edging on the other, makes the side views filled with the lightness on one side and filled with the thickness on the other. Opposed to that, glass half which is light and reduced has very dynamically positioned legs, with distinctively positioned console which holds the glass. For its gentle character, warmer sorts of the wood as cherry, plum or pear perfectly fits to this table.





Coffee table TY, cherry, tempered glass, 02-02-01

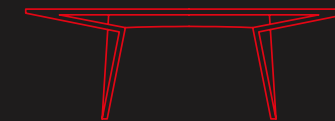

maru coffee table
designer: ranko bocina
launched: 2015.
code: 02-02-04
dimension: w120, l50, h39
finishing: solid wood (natural oil, hard wax)
packaging: five layer cardboard box
1 piece/packaging



mangata coffee table
designer: ranko bocina
launched: 2015.
code: 02-02-05
dimension: w120, l50, h39
finishing: solid wood (natural oil, hard wax)
packaging: five layer cardboard box
1 piece/packaging

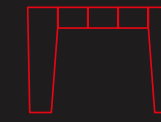

robust coffee table
designer: aleksandar ugresic
launched: 2014.
code: 02-02-02
dimension: w33, l55, h40
finishing: solid wood sandblasted
(natural oil, hard wax)
packaging: five layer cardboard box
1 piece/packaging



Coffee table No 1
designer: aleksandar ugresic
launched: 2014.
code: 02-02-03
dimension: w33, l49, h50
finishing: solid wood (natural oil, hard wax)
packaging: five layer cardboard box
1 piece/packaging

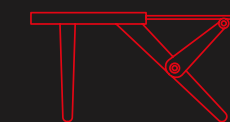

ty coffee table
designer: aleksandar ugresic
launched: 2014.
code: 02-02-01
dimension: w48, l80, h40
finishing: solid wood (natural oil, hard wax)
glass tempered 10mm
metal brassed
packaging: five layer cardboard box
1 piece/packaging



From left to right, table NT04 02-03-04, NT03 02-03-03, NT01 02-03-01

collection

Neqative

010

negative collection

While designing these tables, the basic idea has been the negative concept. The negative effect reflects on the sides, or "the legs" of these tables. Slits which appear on one side of the table, become the legs on the other side and conversely. This collection is composed by the 4 different coffee tables, which can be combined in the various spatial forms, but also can be used separately. It is ideal to be used in the lined forms or as a very playful bench. European walnut or elm fits perfectly to these tables, because of the sharpness of its lines and also their masculine character.

Negativ tables

While designing these table, the basic idea has been the negative concept. The negative effect reflects on the sides, or "the legs" of these tables. Slits which appear on one side of the table, become the legs on the other side and conversely. European walnut or elm fits perfectly to these tables, because of the sharpness of its lines and also their masculine character.





negative coffee table
designer: aleksandar ugresic
launched: 2014.
code: 02-03-01 (-02,-03,-04)
dimension: w39, l56, h46
finishing: solid wood (natural oil, hard wax)
packaging: five layer cardboard box
1 piece/packaging

From left to right, table NT01 02-03-01, NT03 02-03-03, NT02 02-03-02, NT04 02-03-04





Stealth chair, steamed acacia, 03-01-01

011

Stealth

collection

Stealth chair, steamed acacia, 03-01-01
Stealth dining table, steamed acacia, 03-01-02





stealth collection

stealth collection is composed by two types of dining table and chair.

The basic element is the rounded form of a triangle, which flows through all pieces of the collection.

The "Stealth" name comes from the very sharp and emphasized lines of surfaces separations, which make seater part and back rest on the chairs and the table top. Additional dynamic or the effect of "invisibility" is given by the three surfaces of an each triangle, with a 120 degrees position, and also by its mildly angled position to the centre. Conically positioned triangular legs also increase the dynamic of each element.

Apart from the effect of invisibility, this collection is also characterized with the extraordinary lightness and fragility. To increase the static of a solid wood chair weighting less than 4 Kg, steel substructure is built-in the legs and the seater part.

Considering its character, sorts of wood as European walnut and dark elm perfectly fits to this collection.

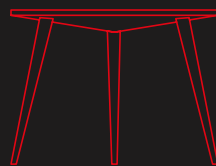

stealth dining table
designer: aleksandar ugresic
launched: 2014
code: 03-01-02
dimension: w100, l87, h73
finishing: solid wood (natural oil, hard wax)
packaging: five layer cardboard box
1 piece/packaging



stealth table
designer: aleksandar ugresic
launched: 2014
code: 03-01-01
dimension: w47, l45, h88
finishing: solid wood (natural oil, hard wax)
packaging: five layer cardboard box
1 piece/packaging

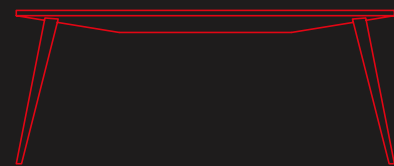

stealth dining table
designer: aleksandar ugresic
launched: 2015
code: 03-01-03
dimension: w160 (180), l90, h73
finishing: solid wood (natural oil, hard wax)
packaging: five layer cardboard box
1 piece/packaging



Stealth chair, steamed acacia, 03-01-01



012

L collection

This collection was created by following the design line of the Negative and Stealth collection which is characterized by clean surface and sharp line. Novelty with this collection, compared to previous one, is the use of elements of steel which as newly-introduced material, fulfills the bulkiness and strictness of form, thus making an effect of sculpture.

L collection consists of: work table, dining table and chairs. The basic idea is combining the 'heavy' materials into light and clean form. Type of wood suitable for this collection is: walnut, dark elm and heat-treated or steamed acacia. Wood finishing techniques imply application of natural oils and wax. The buyer has the option of choosing a type of wood as well as metal finishing (ie painted, gun-metal, patina - copper finish).





Dining table, steamed acacia, metal bronze colored, 03-02-02

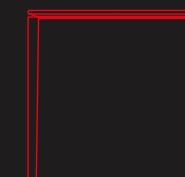

L dining table
designer: jelena ugresic
launched: 2014.
code: 03-02-02
dimension: w160 (180,200,220), l80 (90), h75
finishing: solid wood (natural oil, hard wax)
metal coloured
packaging: five layer cardboard box
1 piece/packaging
dismantling



L chair
designer: aleksandar ugresic
launched: 2014.
code: 03-02-01
dimension: w53, l52, h88
finishing: solid wood (natural oil, hard wax)
metal coloured
packaging: five layer cardboard box
1 piece/packaging



From left to right, chair, acacia, steamed acacia, acacia, metal colored, 03-02-01



STOOL
TOOL
HOOKE
UN



Chair, acacia, metal coloured, 03-02-01
Dining table, acacia, metal coloured, 03-02-02



Dining table kaminari, eu walnut, 160x80cm, 03-03-01

013

collection

Dining Table



kaminari dining table

Dining table made from solid wood designed with the idea of the obvious savings of materials and of a construction that does not interrupt the stability and overall structural integrity. Maximum facilitated leg is the backbone of the entire idea where connectivity achieved in several points in space makes extremely stable the place of connecting legs and plate, where the longitudinal lateral support is transferred into a diagonal. The panel thickness of 25mm by reduced processing makes it look even thinner and the overall impression and experience gives special lightness. Purified aesthetics is applicable for areas of contemporary artistic architectural treatment. Its production is anticipated in longitudinal variations in the situation of different capacities of the users, or the interiors of different needs and conditions of use.

Dining table kaminari, eu walnut, 160x80cm, 03-03-01
L chair, steamed acacia, metal bronze colored, 03-02-01

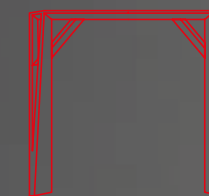

kaminari dining table
designer: boris bocina
launched: 2015.
code: 03-03-01
dimension: w160 (180,200,220), l80 (90), h75
finishing: solid wood (natural oil, hard wax)
packaging: five layer cardboard box
1 piece/packaging



Dining table kaminari, eu walnut, 160x80cm, 03-03-01
L chair, steamed acacia, metal bronze colored, 03-02-01





Bar stool high, acacia, metal colored, 04-02-02

014

Clover
collection



left, bar stool low, eu walnut, 04-01-01
right, bar stool high, acacia, metal colored, 04-01-02
bar table, acacia, 04-01-03





bar stool high, acacia, metal colored, 04-01-02
bar table, acacia, 04-01-03

clover collection

This collection consists of bar table and two types of bar stools (standard high or low). This collection is inspired by constructive-like character of stool by Lise Johansson – Pape. Rounded lines of Scandinavian stool design, has got in this collection a sharper, industry-like shape.



left, bar stool high, acacia, metal colored 04-01-02
right, bar stool low, eu walnut, 04-01-01



high bar stool
designer: aleksandar ugresic
launched: 2014.
code: 04-01-02
dimension: w52, l34, h77
finishing: solid wood (natural oil, hard wax),
metal coloured
packaging: five layer cardboard box
1 piece/packaging



low bar stool
designer: aleksandar ugresic
launched: 2014.
code: 04-01-01
dimension: w52, l34, h63
finishing: solid wood (natural oil, hard wax)
packaging: five layer cardboard box
1 piece/packaging



left, bar stool low, eu walnut, 04-01-01
right, bar stool high, acacia, metal colored, 04-01-02



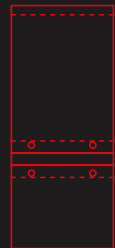

bar table
designer: aleksandar ugresic
launched: 2014.
code: 04-01-03
dimension: w125, l42, h100
finishing: solid wood (natural oil, hard wax),
metal coloured
packaging: five layer cardboard box
1 piece/packaging





Commode, cherry, concrete natural, 05-01-01

015

collection

concrete



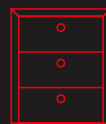

commode
designer: aleksandar ugresic
launched: 2014.
code: 05-01-01
dimension: w40, l35, h46
finishing: solid wood (natural oil, hard wax),
concrete natural
packaging: five layer cardboard box
1 piece/packaging





totem lamp, eu walnut, 06-01-02

016

lamps

collection

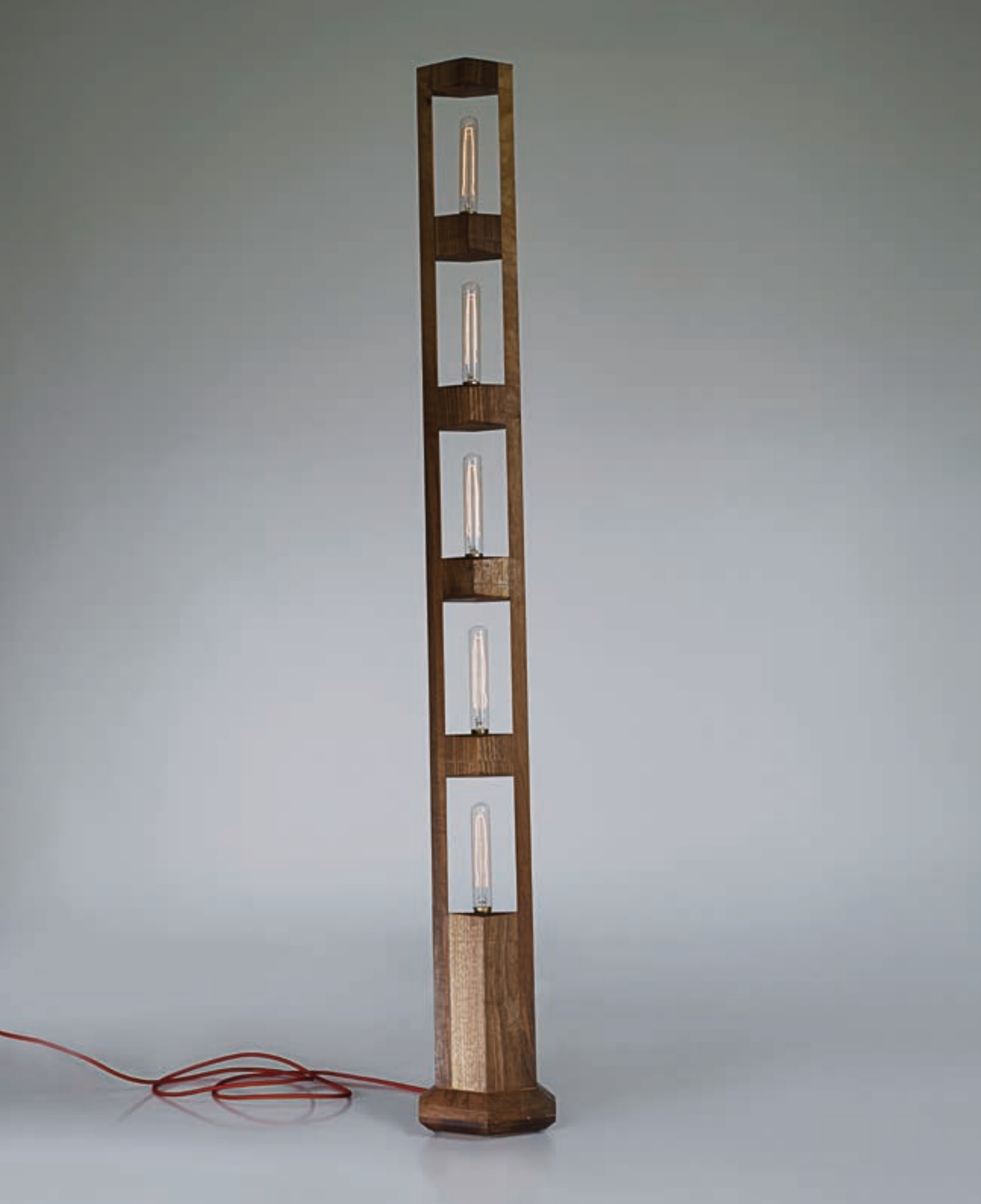

totem lamp, eu walnut, edison bulbs 5x40w, 06-01-02

Lamps comprise several collections: Totem, Relife, Prayer and T-rex. Totem and Relife lamps are offered in the version of self-supported floor lamp and pendant light.

Prayer is offered in the version of the wall, self-supported, floor lamp and pendant light, while T-rex lamp is a self-supported floor lamp.

Majority of lamps is made in combination of wood and steel. Common trait is that they use as source of light the decorative antique bulbs of different shape, with Edison fiber inside, which gives exceptionally warm, yellow-orange tone. Because of the characteristic shapes of these bulbs (balloon or tube), they make, for the most part, not only functional, but very important esthetic element of each lamp.

In order to emphasize retro look of each lamp, we used threaded-intertwined electricity cables in variety of different colours.



totem lamp
designer: aleksandar ugresic
launched: 2015.
code: 06-01-02
dimension: w20, l42, h163
finishing: solid wood (natural oil, hard wax)
packaging: five layer cardboard box
1 piece/packaging



relife lamp, eu walnut solid wood, holder steel natural, edison bulbs 6x40w, 06-01-01

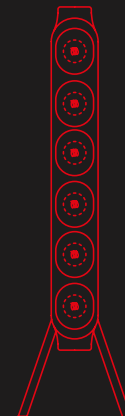

relife lamp
designer: aleksandar ugresic
launched: 2015.
code: 06-01-01
dimension: w45, l56, h180
finishing: solid wood (natural oil, hard wax),
metal natural
packaging: five layer cardboard box
1 piece/packaging

...designers



Aleksandar Ugresic
Serbian, born in Belgrade in 1974. He has studied pharmacy and he is owner-director of pharmaceutical manufacturing company named UFAR.. As a successful businessman with more than 15 years of experience in his own business and with a great passion for design and photography, in the year of 2012 he has established a workshop for producing handmade solid wood furniture, named HOOKL und STOOL. With a basic esthetical idea based on the postwar Royal Scandinavian school postulates as a guide, he tried himself in designing solid wood furniture. By far, he has several successfully done projects.



Zoran Jedrejic
Croatian, born in Split, designer. He has studied architecture and industrial design at the University of Zagreb, Croatia; ISIA of Florence, Italy and Hochschule der Bildenen Kunste Saar of Saarbrücken, Germany. After seven years of fruitful cooperation with Ettore Sottsass he opened his own design studio in Milan and recently one in Belgrade. He has designed for many world brands, like 3M, Artisan, BRF Colors, Dada Cucine, Fratelli Guzzini, Magppie, Molteni&C, Nambé, Segis, and others. He has won several Red Dot and IF Design Awards, and his works have been exhibited in famous museums like MAK Wien, ICA Boston, MoMA NY, Ozone Centre Tokyo, etc.



Dipl. arch. Boris Bocina
Born in 1988 in Belgrade, Serbia. He studied and graduated in interior and furnituredesign on the same department of the Faculty of Applied Arts, Belgrade University of Arts. Since 2013 teaches at the School of Design in Belgrade, department of industrial design and interior design. In addition to interior and furniture design, which is his primary area of activity significant successes in the fields of industrial, urban and graphic design. He participates in numerous public tenders in these areas. Models is in the tradition of creativity Scandinavian and Japanese rationality that inspiring associated with natural bionic principles and logic in shaping wood.



Jelena Ugresic
Born in 1975 in Krusevac, Serbia; studied and graduated from the Faculty of Architecture in Belgrade. Worked for "Perpetuo" studio of architect Vanja Miletic till 2009; from 2009 – 2013 worked for arch. studio "Mitarh" of prof. Branislav Mitrovic. Currently works as freelance designer in the field of interior design; employed as Art Director and designer by Hookl und Stoll.

Dipl. arch Ranko Bocina
Architect Ranko Bocina is a full Professor at the Faculty of Applied Arts in Belgrade, in the Department of Furniture design. He focuses on the design of furniture of all types and purposes, as well as interior design. Bocina participates in public competitions at the field of furniture design, graphic design and urban planning. Furthermore, he has won many awards and acknowledgements independantly or in a team. For HOOKL und STOOL he has created a series of tables in solid wood with very simple and contemporary form (character).



...materials

solid wood standard

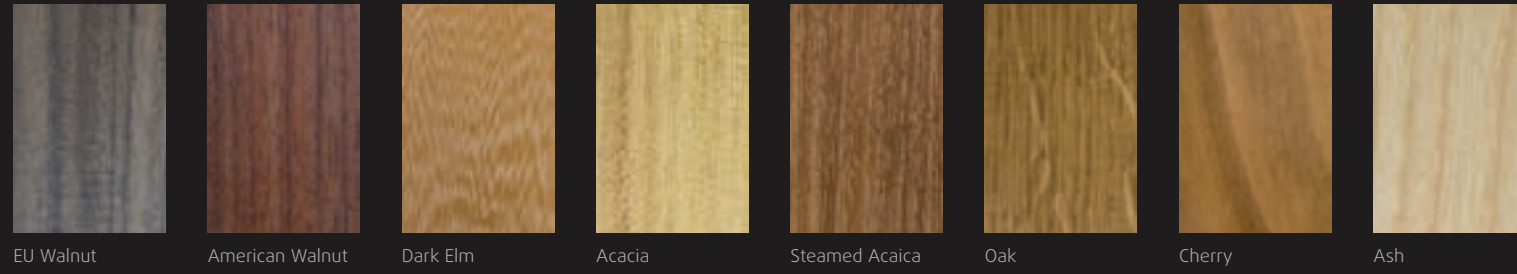

handwoven fabric

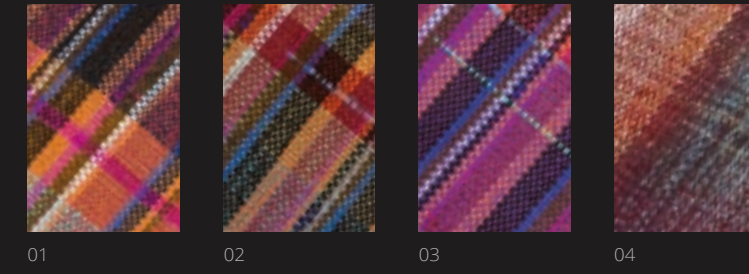

solid wood on request

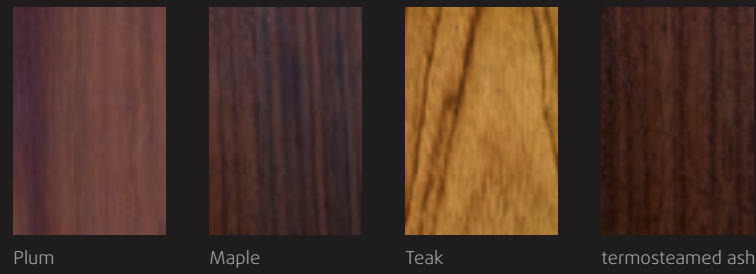

thick leather



fabric



fur

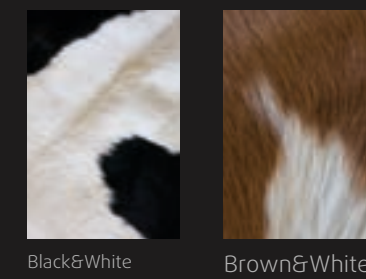

wool fabric



upholstery leather - sequoia



upholstery leather - nubuck

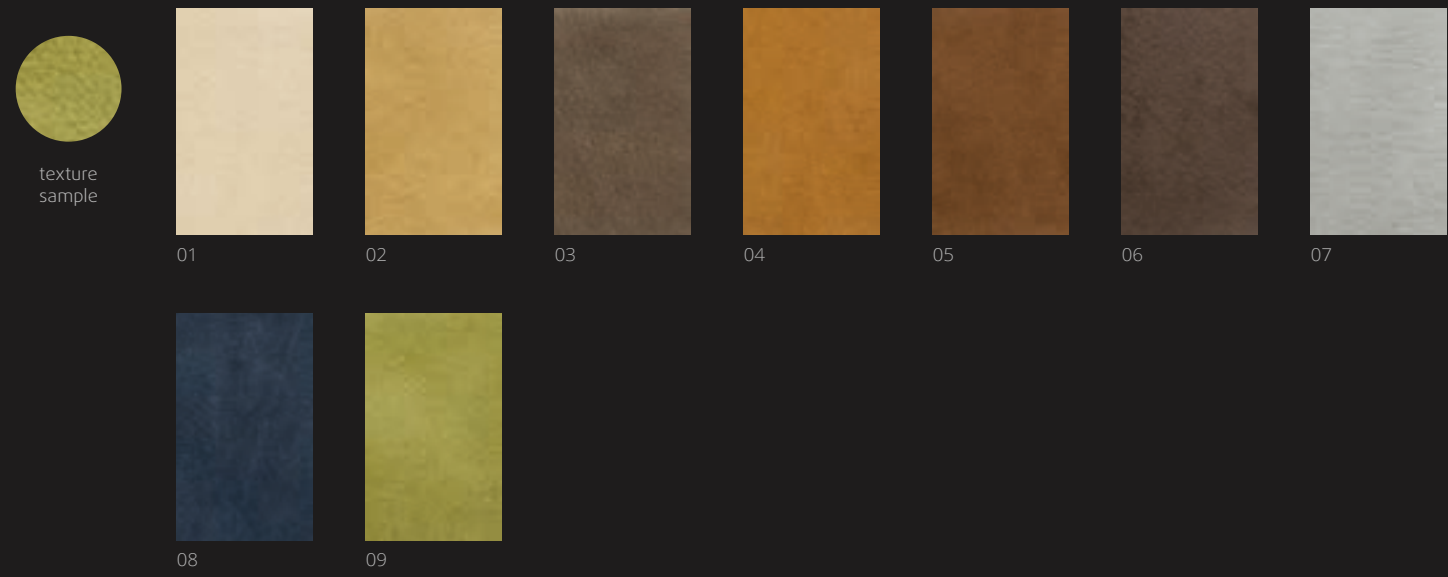

upholstery leather - touch

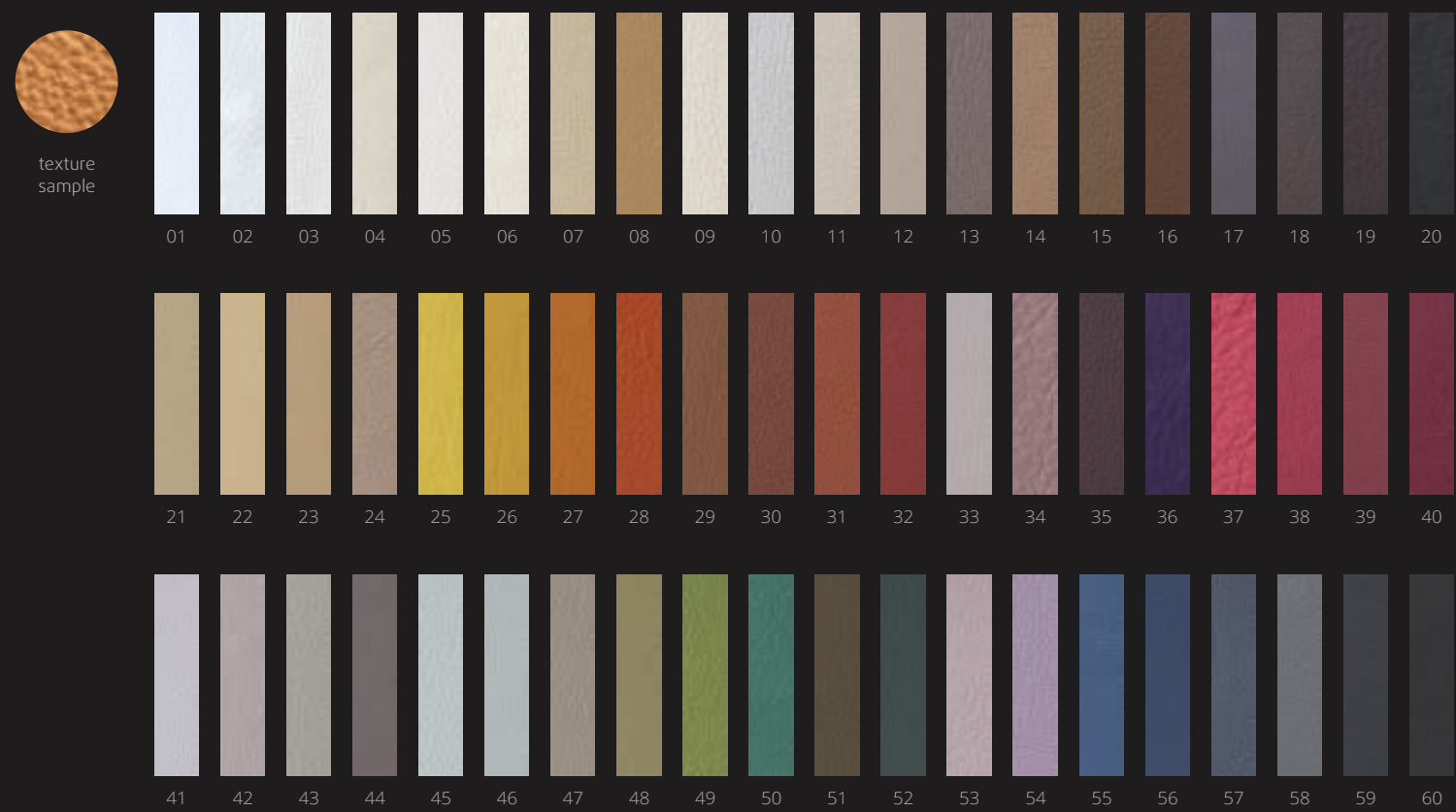

...specs



minas high armchair

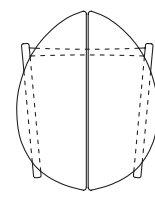
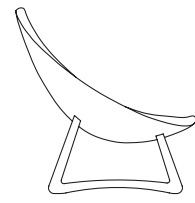
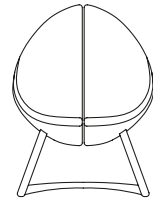

designer: aleksandar ugresic
launched: 2015
code: 01-01-02
dimension: w75, l98, h99
finishing: legs solid wood, seat fabric
packaging: ive layer cardboard box
1 piece/packaging

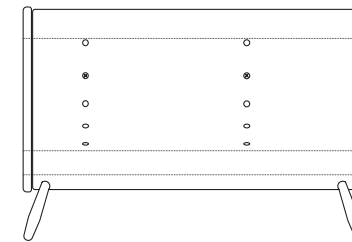

eye sofa

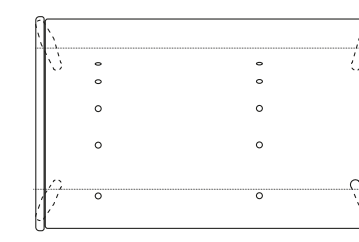
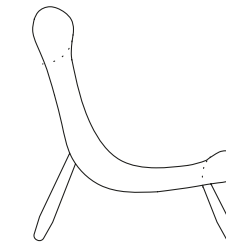

designer: eye sofa
launched: 2015
code: 01-03-05
dimension: w144, l88, h99
finishing: solid wood (natural oil, hard wax), seat fabric, wool
packaging: five layer cardboard box
1 piece/packaging



crocodile high armchair 01

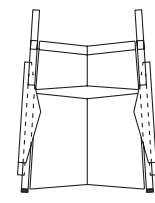
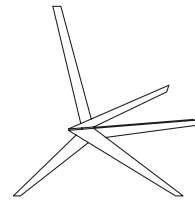
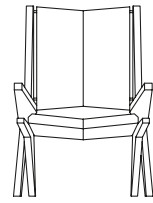

designer: aleksandar ugresic
launched: 2015
code: 01-02-02
dimension: w74, l92, h99
finishing: legs solid wood (natural oil, hard wax), seat fabric, wool
packaging: five layer cardboard box
1 piece/packaging



eye foot rest

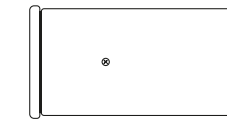
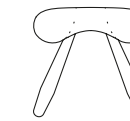
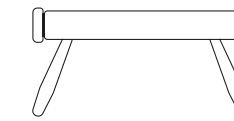

designer: aleksandar ugresic
launched: 2014
code: 01-03-04
dimension: w75, l39, h40
finishing: solid wood (natural oil, hard wax)
packaging: packed with armchair



crocodile high armchair 02

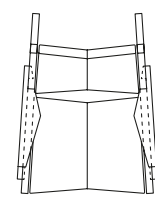
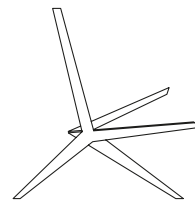
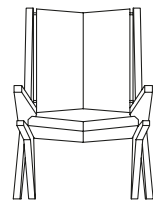

designer: aleksandar ugresic
launched: 2015
code: 01-02-06
dimension: w74, l92, h99
finishing: legs solid wood (natural oil, hard wax), seat fabric, wool
packaging: five layer cardboard box
1 piece/packaging



armada high armchair

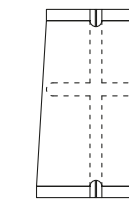
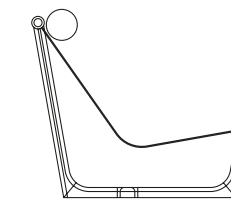
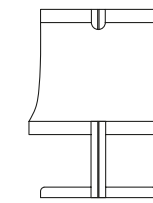

designer: zoran jedrejic
launched: 2014
code: 01-04-01
dimension: w60, l95, h80
finishing: legs solid wood (natural oil, hard wax), seat thick leather
packaging: five layer cardboard box
1 piece/packaging



crocodile coffee table

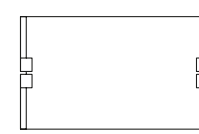
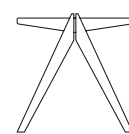

designer: aleksandar ugresic
launched: 2014
code: 01-02-05
dimension: w65, l39, h39
finishing: solid wood (natural oil, hard wax)
packaging: five layer cardboard box
1 piece/packaging



armada foot rest

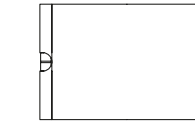
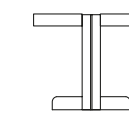
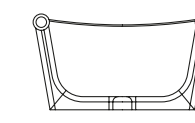

designer: zoran jedrejic
launched: 2014
code: 01-04-03
dimension: w60, l37, h33
finishing: solid wood (natural oil, hard wax), seat thick leather
packaging: packed with armchair



eye high armchair

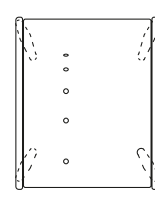
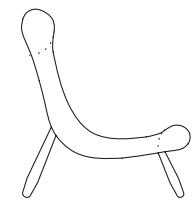
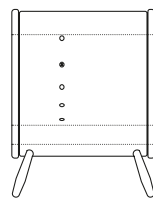

designer: aleksandar ugresic
launched: 2015
code: 01-03-02
dimension: w75, l88, h99
finishing: legs solid wood (natural oil, hard wax), seat fabric, wool
packaging: five layer cardboard box
1 piece/packaging



armada coffee table

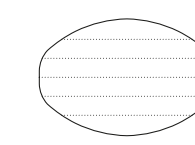
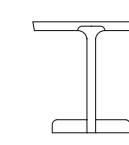
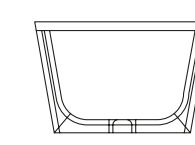

designer: zoran jedrejic
launched: 2014
code: 01-04-05
dimension: w60, l95, h80
finishing: solid wood (natural oil, hard wax)
packaging: five layer cardboard box
1 piece/packaging



layair o1 high armchair

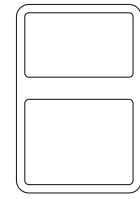
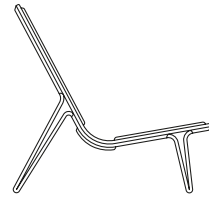
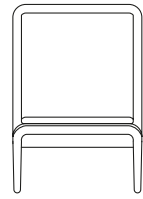

designer: zoran jedrejic
launched: 2014
code: 01-05-01
dimension: w60, l95, h87
finishing: solid wood (natural oil, hard wax), seat fabric, wool, leather, handwoven on request
packaging: five layer cardboard box 1 piece/packaging



layair o2 high armchair

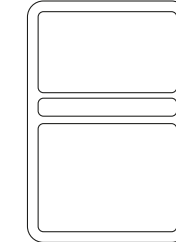
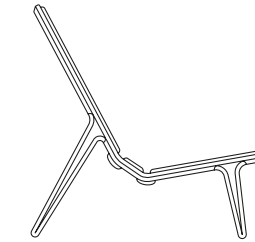
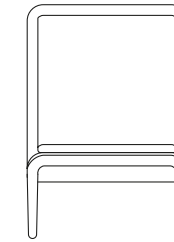

designer: zoran jedrejic
launched: 2014
code: 01-06-01
dimension: w60, l95, h87
finishing: solid wood (natural oil, hard wax), seat fabric, wool, leather, handwoven on request
packaging: five layer cardboard box 1 piece/packaging



layair o1 low armchair

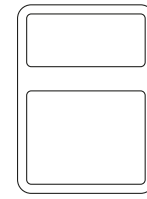
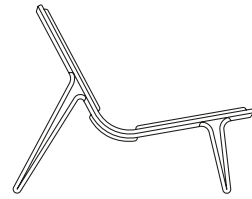
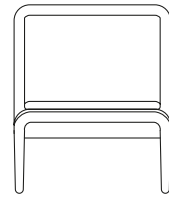

designer: zoran jedrejic
launched: 2014
code: 01-05-05
dimension: w60, l91, h71
finishing: solid wood (natural oil, hard wax), seat fabric, wool, leather, handwoven on request
packaging: five layer cardboard box 1 piece/packaging



layair o2 low armchair

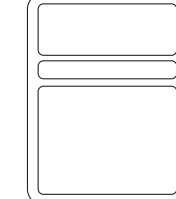
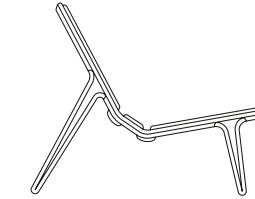
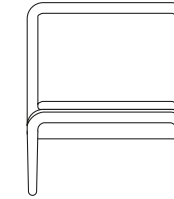

designer: zoran jedrejic
launched: 2014
code: 01-06-05
dimension: w60, l91, h71
finishing: solid wood (natural oil, hard wax), seat fabric, wool, leather, handwoven on request
packaging: five layer cardboard box 1 piece/packaging



layair foot rest

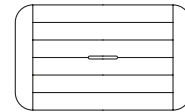
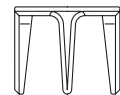
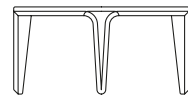

designer: zoran jedrejic
launched: 2014
code: 01-05-09 (01-06-09)
dimension: w36, l60, h32
finishing: solid wood (natural oil, hard wax), seat fabric, wool, leather, handwoven on request
packaging: packed with armchair



masterpiece MP01

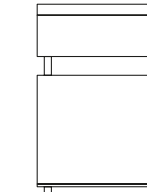
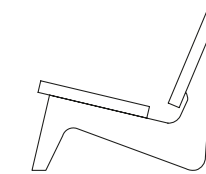
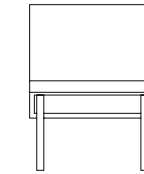

designer: cees brakman
code: 01-07-01
dimension: w53, l73, h70
finishing: solid wood (natural oil, hard wax)
packaging: five layer cardboard box 1 piece/packaging



layair coffee table

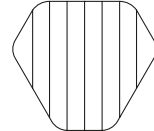
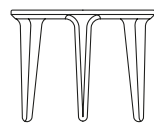

designer: zoran jedrejic
launched: 2014
code: 01-05-18 (01-06-18)
dimension: w36, l60, h32
finishing: solid wood (natural oil, hard wax)
packaging: five layer cardboard box 1 piece/packaging



masterpiece MP02

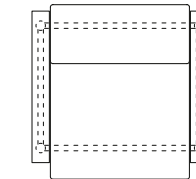
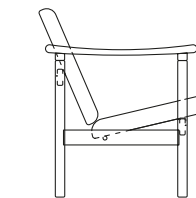
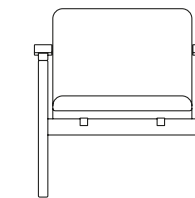

designer: hans wegner
code: 01-07-02
dimension: w71, l74, h75
finishing: solid wood (natural oil, hard wax), seat fur
packaging: five layer cardboard box 1 piece/packaging



layair stool

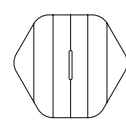
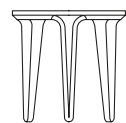

designer: zoran jedrejic
launched: 2014
code: 01-05-13 (01-06-13)
dimension: w40, l36, h38
finishing: solid wood (natural oil, hard wax), seat fabric, wool, leather, handwoven on request
packaging: five layer cardboard box 1 piece/packaging



masterpiece MP03

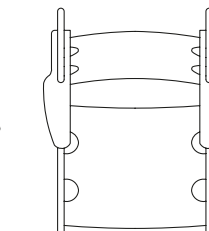
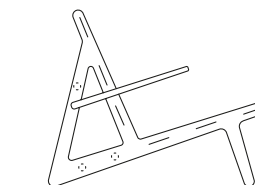
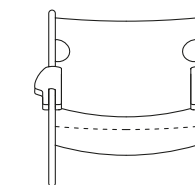

designer: børge mogensen
code: 01-07-03
dimension: w70, l90, h68
finishing: solid wood (natural oil, hard wax), seat thick leather
packaging: five layer cardboard box 1 piece/packaging



masterpiece MP04

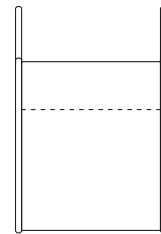
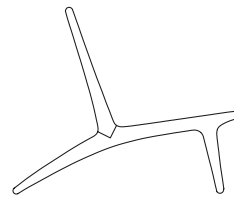
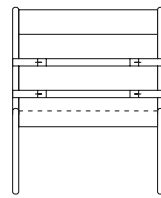

designer: uno & östen kristiansson
code: 01-07-04
dimension: w62, l100, h78
finishing: solid wood (natural oil, hard wax), seat thick leather
packaging: five layer cardboard box 1 piece/packaging



maru coffee table

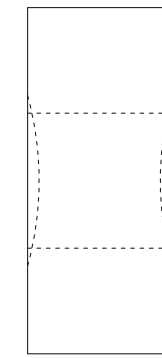
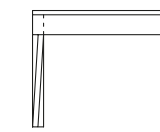
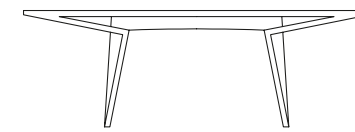

designer: ranko bocina
launched: 2015.
code: 02-02-04
dimension: w120, l50, h39
finishing: solid wood (natural oil, hard wax)
packaging: five layer cardboard box 1 piece/packaging



masterpiece MP05

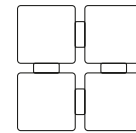
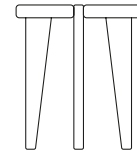
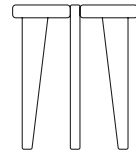

designer: lisa johansson pape
code: 01-07-05 (01-07-06)
dimension: low w28, l28, h35
high w39, l39, h45
finishing: solid wood (natural oil, hard wax)
packaging: five layer cardboard box 1 piece/packaging



mangata coffee table

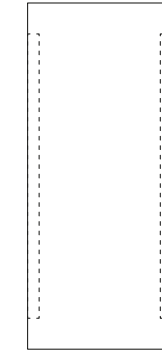
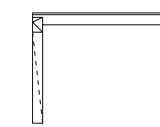
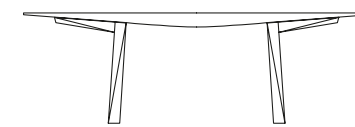

designer: ranko bocina
launched: 2015.
code: 02-02-05
dimension: w120, l50, h39
finishing: solid wood (natural oil, hard wax)
packaging: five layer cardboard box 1 piece/packaging



Polyline No1

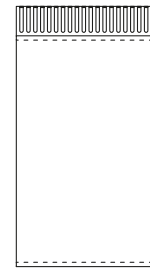
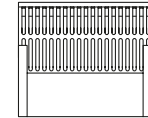
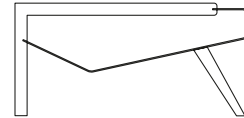

designer: aleksandar ugresic
launched: 2015
code: 02-01-01
dimension: w80, l47, h39
finishing: solid wood (natural oil, hard wax), metal colored steel
packaging: five layer cardboard box 1 piece/packaging



robust coffee table

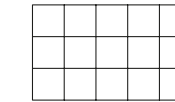
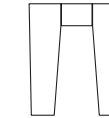
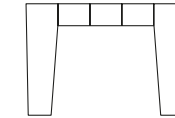

designer: aleksandar ugresic
launched: 2014.
code: 02-02-02
dimension: w33, l55, h40
finishing: solid wood sandblasted (natural oil, hard wax)
packaging: five layer cardboard box 1 piece/packaging



Polyline No2

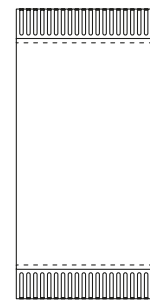
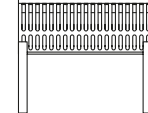
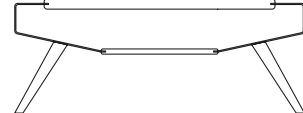

designer: aleksandar ugresic
launched: 2015
code: 02-01-02 (02-01-03)
dimension: small w100, l47, h39
big w120, l60, h39
finishing: solid wood (natural oil, hard wax), metal colored steel
packaging: five layer cardboard box 1 piece/packaging



Coffee table No1

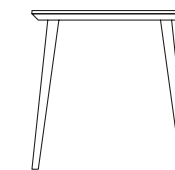

designer: aleksandar ugresic
launched: 2014.
code: 02-02-03
dimension: w33, l49, h50
finishing: solid wood (natural oil, hard wax)
packaging: five layer cardboard box 1 piece/packaging



Polyline hi-fi rack

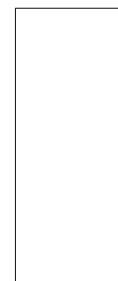
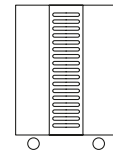
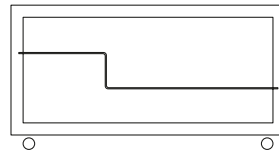

designer: aleksandar ugresic
launched: 2015
code: 02-01-04
dimension: small w95, l36, h50
big w135, l36, h50
finishing: solid wood (natural oil, hard wax), metal colored steel
packaging: five layer cardboard box 1 piece/packaging



ty coffee table

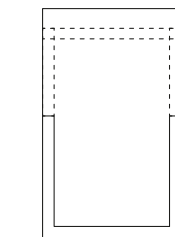
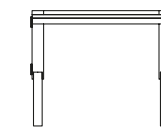
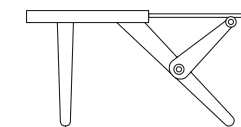

designer: aleksandar ugresic
launched: 2014.
code: 02-02-01
dimension: w48, l80, h40
finishing: solid wood (natural oil, hard wax)
glass tempered 10mm metal brassed
packaging: five layer cardboard box 1 piece/packaging



negative coffee table

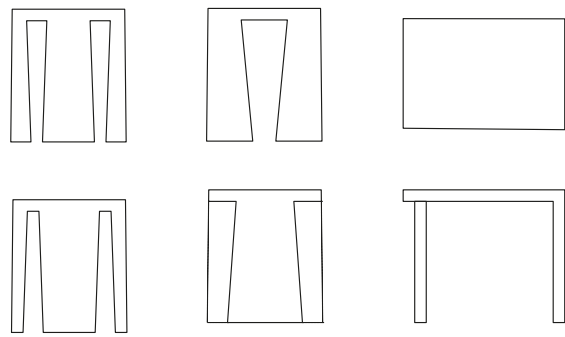

designer: aleksandar ugresic
launched: 2014.
code: 02-03-01 (-02,-03,-04)
dimension: w39, l56, h46
finishing: solid wood (natural oil, hard wax)
packaging: five layer cardboard box
1 piece/package



L chair

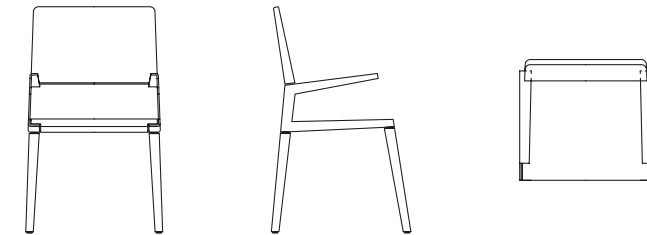

designer: aleksandar ugresic
launched: 2014.
code: 03-02-01
dimension: w53, l52, h88
finishing: solid wood (natural oil, hard wax)
metal coloured
packaging: five layer cardboard box
1 piece/package



stealth dining table

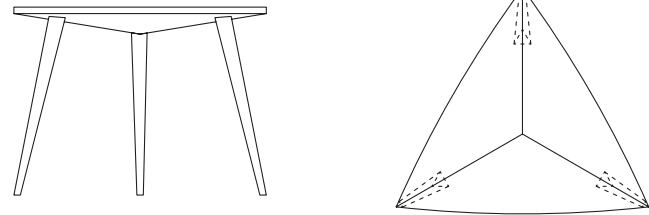

designer: aleksandar ugresic
launched: 2014
code: 03-01-02
dimension: w100, l87, h73
finishing: solid wood (natural oil, hard wax)
packaging: five layer cardboard box
1 piece/package



kaminari dining table

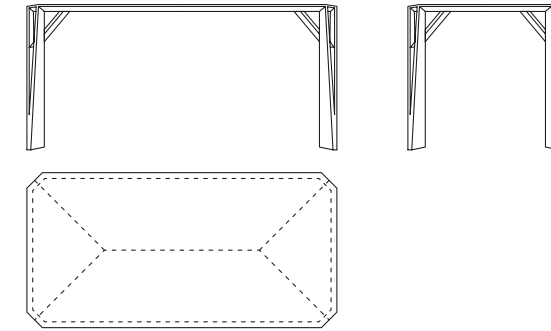

designer: boris bocina
launched: 2015.
code: 03-03-01
dimension: w160, l80, h75
finishing: solid wood (natural oil, hard wax)
packaging: five layer cardboard box
1 piece/package



stealth chair

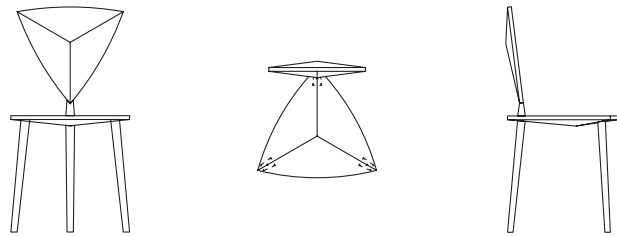

designer: aleksandar ugresic
launched: 2014
code: 03-01-01
dimension: w47, l45, h88
finishing: solid wood (natural oil, hard wax)
packaging: five layer cardboard box
1 piece/package



clover low bar stool

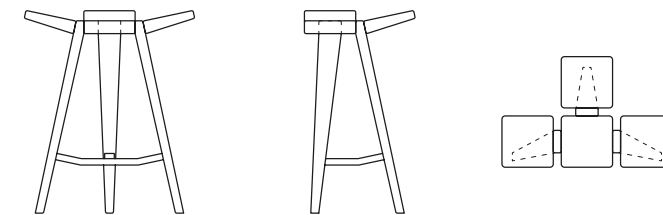

designer: aleksandar ugresic
launched: 2014.
code: 04-01-01
dimension: w52, l34, h63
finishing: solid wood (natural oil, hard wax), metal coloured
packaging: five layer cardboard box
1 piece/package

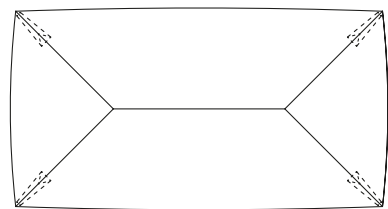

stealth dining table

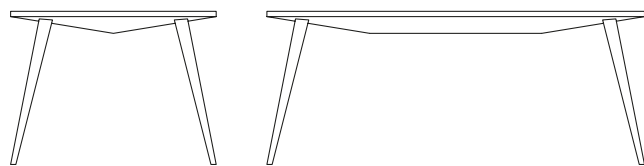

designer: aleksandar ugresic
launched: 2015
code: 03-01-03
dimension: w160 (180), l90, h73
finishing: solid wood (natural oil, hard wax)
packaging: five layer cardboard box
1 piece/package



clover high bar stool

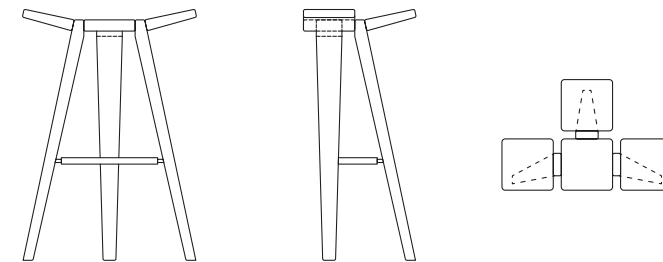

designer: aleksandar ugresic
launched: 2015
code: 04-01-02
dimension: w52, l34, h77
finishing: solid wood (natural oil, hard wax)
packaging: five layer cardboard box
1 piece/package



L dining table

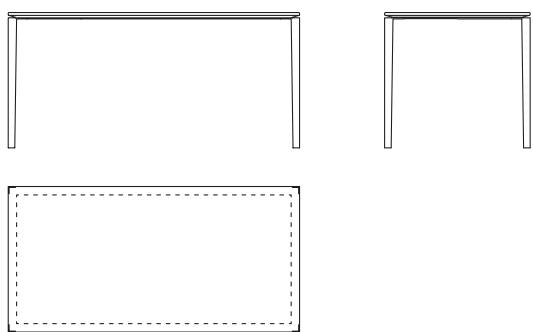

designer: jelena ugresic
launched: 2014.
code: 03-02-02
dimension: w160 (180,200,220), l80 (90), h75
finishing: solid wood (natural oil, hard wax)
metal coloured
packaging: five layer cardboard box
1 piece/package
dismantling



bar table

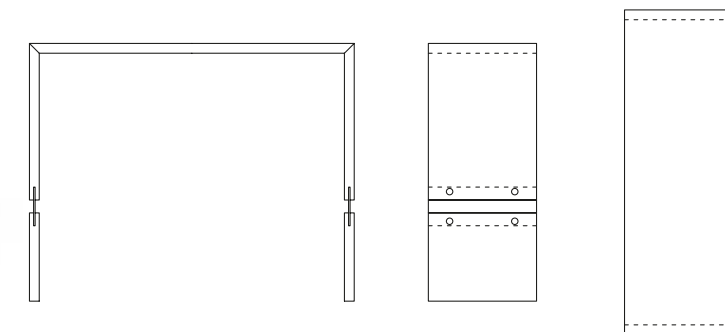

designer: aleksandar ugresic
launched: 2014.
code: 04-01-03
dimension: w125, l42, h100
finishing: solid wood (natural oil, hard wax), metal coloured
packaging: five layer cardboard box
1 piece/package



concrete collection

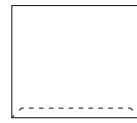
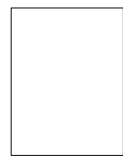
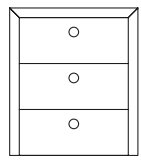

designer: aleksandar ugresic
 launched: 2014.
 code: 05-01-01
 dimension: w40, l35, h46
 finishing: solid wood (natural oil, hard wax), concrete natural
 packaging: five layer cardboard box
 1 piece/packaging



totem lamp

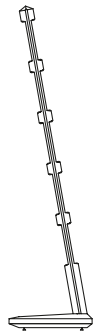

designer: aleksandar ugresic
 launched: 2015.
 code: 06-01-02
 dimension: w20, l42, h163
 finishing: solid wood (natural oil, hard wax)
 packaging: five layer cardboard box
 1 piece/packaging



relife lamp

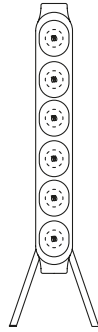
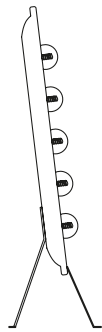

designer: aleksandar ugresic
 launched: 2015.
 code: 06-01-01
 dimension: w45, l56, h180
 finishing: solid wood (natural oil, hard wax), metal natural
 packaging: five layer cardboard box
 1 piece/packaging



www.hooklundstool.com

design by: aleksandar & jelena ugresic

technical editing: nikola bilanovic

photography: nebojsa babic, milan josipovic, aleksandar ugresic

printing and binding: www.vizartis.rs

october 2015.g.